

REV.	DESCRIPTION	ENGR	DATE
1	First Release	RRB	11/15/2022

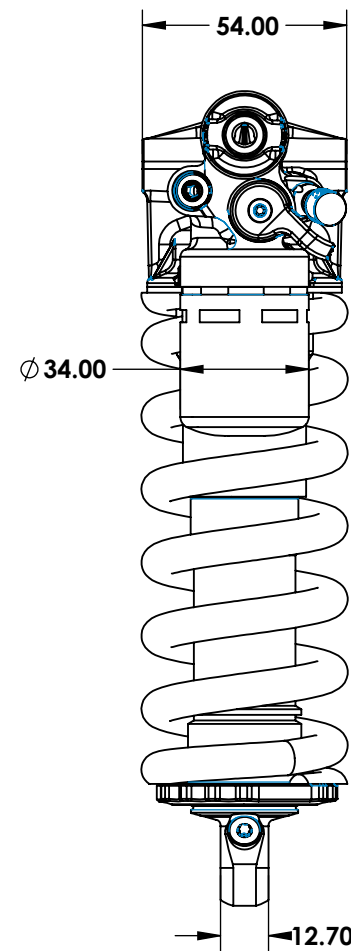

**185mm Eye to Eye
Fully Extended**

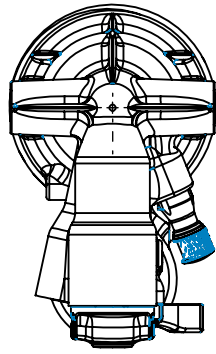
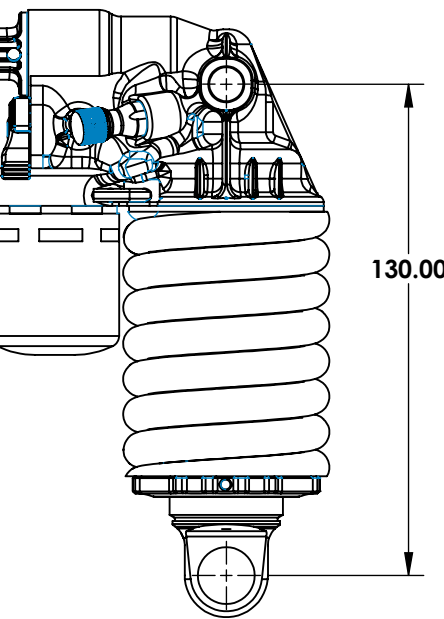
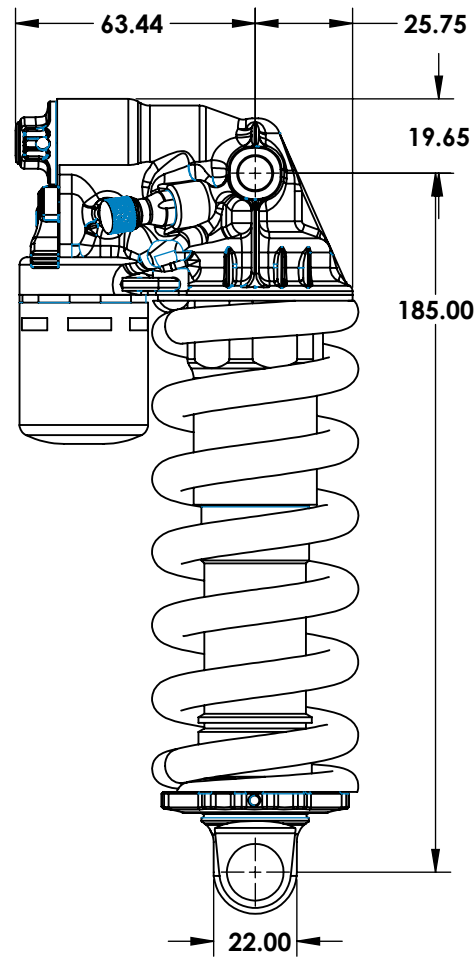

185x55 Fully Compressed

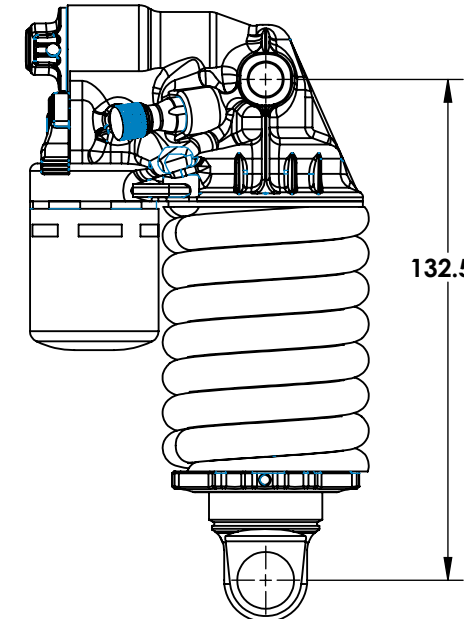

185x52.5 Fully Compressed

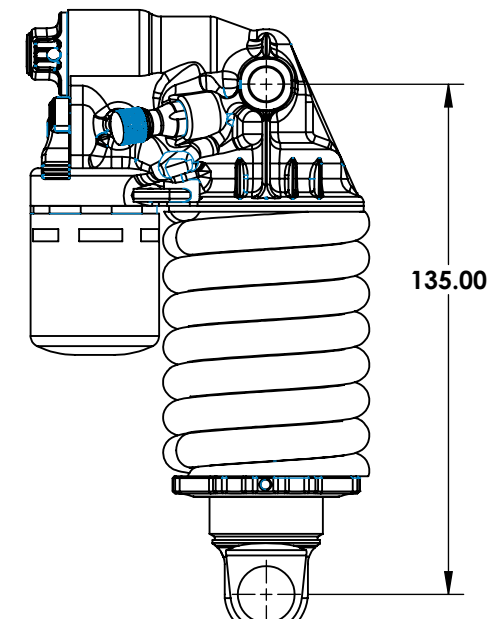

185x50 Fully Compressed

NOTES: UNLESS OTHERWISE SPECIFIED

1. CANE CREEK RESERVES THE RIGHT TO CHANGE SPECIFICATIONS WITHOUT PRIOR NOTICE. DRAWING NOT TO SCALE
2. MINIMUM RECOMMENDED FRAME CLEARANCE: 2.5MM. CUSTOMER IS RESPONSIBLE FOR ENSURING CLEARANCE
3. Coil Spring OD ranges from 51mm-57mm dependant on spring weight.
4. 30 PSI maximum pressure in Ramp Tube.

<p>mm Dimensions</p> <p>Tolerances: .X ± 0.3 .XX ± 0.10 .XXX ± 0.05</p> <p>Angular: ± 0.5 Concentricity: 0.10</p> <p>Third Angle Projection</p>	<p>This drawing and all information therein is the property of Cane Creek Cycling Components and is confidential and must not be made public or copied. It is loaned subject to return upon demand and is not to be used in any way that is detrimental to our interests.</p>	
<p>Material:</p> <p>Weight:</p> <p>Finish:</p>	<p>TITLE: DB Tigon User Spec Drawing</p>	<p>SIZE: B</p> <p>Part No.: 185mm Trunnion</p> <p>REV.: 01</p>
<p>Color:</p>	<p>SCALE: 1:2</p>	<p>SHEET 1 OF 1</p>